

 **IF 4K™**



Instruction Manual

Interferential Therapy

Thank You Note

Thank you for choosing IF 4K which provides an interferential therapy to treat conditions where inflammation is a problem such as Back Pain, Osteoarthritis, Rheumatoid Arthritis, Muscular Pain / Strain, and Sports injuries. IF 4K produces the low frequency current treatment that uses two medium frequency currents, which “interfere” with each other to produce a beat frequency that the body recognizes as a low frequency energy source.

The rationale is to overcome the problems caused by low-frequency currents, while maintaining their claimed therapeutic effect. Unlike TENS, which delivers intermittent pulses to stimulate surface nerves and block the pain signal, Interferential Current Therapy delivers continuous stimulation deep into the affected tissue.

The actual stimulation is produced by crossing two alternating currents with medium frequencies simultaneously to a targeted body region. As a result, these two currents will superimpose to form a new low frequency current deep within the tissue.

IF 4K includes:

- 1 x IF 4K device
- 2 x Lead Wire
- 4 x Electrodes
- 4 x Battery
- 1x Adaptor
- 1 x AC Plug
- 1 x Belt clip
- 1 x Instruction manual

CONTENTS

| | |
|---------------------------------|-----|
| 1. Safety Information..... | 1-3 |
| 2. Operation keys..... | 4 |
| 3. LCD Display..... | 5 |
| 4. Operations..... | 6-9 |
| 5. Treatment Programs..... | 10 |
| 6. Placement of Electrodes..... | 11 |
| 7. Battery replacement..... | 12 |
| 8. Maintenance..... | 12 |
| 9. Warranty..... | 13 |
| 10. Device failures..... | 13 |
| 11. Trouble shooting..... | 14 |
| 12. Specification..... | 15 |
| 13. Important symbols..... | 16 |

1. Safety Information



Attention! Read the manual before using the device.

Contraindications

1. Any electrode placement that applies current to the carotid sinus (neck) region.
2. Any use of TENS on patients who have a cardiac pacemaker, implanted defibrillator, or other implanted metallic or electronic device, because this may cause electric shock, burns, electrical interference, or death.
3. Any electrode placement that causes current to flow transcranially (through the head).
4. The use of TENS whenever pain syndromes are undiagnosed, until etiology is established.

Warnings

1. The safety of TENS devices for use during pregnancy or birth has not been established.
2. TENS is not effective for pain of central origin (This includes headache).
3. TENS devices should be used only under the continued supervision of a physician.
4. It is recommended that patients consult with their physician before using this device, because the device may cause lethal rhythm disturbances to the heart in susceptible individuals.
5. TENS devices have no curative value.



Attention! Read the manual before using the device.

6. TENS is a symptomatic treatment and as such suppresses the sensation of pain which would otherwise serve as a protective mechanism.
7. The user must keep this device out of the reach of children.
8. Electronic monitoring equipment (such as ECG monitors and ECG alarms may not operate properly when TENS stimulation is in use.
9. Stimulation should not be applied across the patient's chest, because the introduction of electrical current into the chest may cause rhythm disturbances to the patient's heart, which could be lethal.
10. Stimulation should not be applied over open wounds or over swollen, infected or inflamed areas or skin eruptions (e.g., phlebitis, thrombophlebitis, varicose veins). Apply stimulation only to normal, intact, clean skin.
11. Stimulation should not be applied over, or in proximity to, cancerous lesions.
12. Stimulation should not be applied when the patient is in the bath or shower.
13. Stimulation should not be applied while the patient is sleeping.
14. Stimulation should not be applied while the patient is driving, operating machinery, or during any activity in which electrical stimulation can put the patient at risk of injury.

Precautions

1. Isolated cases of skin irritation may occur at the site of electrode placement following long term application.
2. Effectiveness is highly dependent upon patient selection by a person qualified in the



Attention! Read the manual before using the device.

management of pain patients.

3. TENS is not a substitute for pain medications and other pain management therapies.
4. The long-term effects of electrical stimulation are unknown.
5. Patients with suspected or diagnosed heart disease should follow precautions recommended by their physicians.
6. Patients with suspected or diagnosed epilepsy should follow precautions recommended by their physicians.
7. Caution should be exercised when the patient has a tendency to bleed internally, such as following an injury or fracture.
8. Caution should be exercised following recent surgical procedures when stimulation may disrupt the patient's healing process.
9. Caution should be exercised when stimulating over areas of skin that lack normal sensation.
10. Use this device only with the leads, electrodes, and accessories recommended by the manufacturer.

Adverse Reactions

1. Skin irritation and electrode burns are potential adverse reactions.
2. Headache and other painful sensations have been reported during or following the application of electrical stimulation near the eyes and to the head and face.

2. Operation keys



1. ON/OFF

T Turns the device on and off.

2. INCREASE INTENSITY

p Press this button to increase amplitude. (intensity of stimulation)

3. DECREASE INTENSITY

p Press this button to decrease amplitude. (intensity of stimulation)

4. INCREASE FREQUENCY

p Press this button to increase frequency.

5. DECREASE FREQUENCY

p Press this button to decrease frequency.

6. PROGRAM

6 Programs. Select program from P1 to P6.

1. 7. TIMER

Click once to select the next available timer value. i.e. continuous → 15 min → 30 min → 45 min → 60 min → continuous. If program is locked, TIMER KEY can't work. Press & hold for 2 seconds to display USAGE TIMER DISPLAY stated.

8. 2/4 PAD, KEY LOCK

Click once to select for 2 or 4 pads. Press & hold for 2 seconds to lock or unlock a program.

3. LCD Display

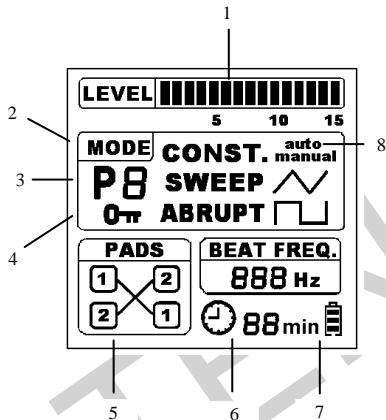

1. LEVEL BAR

T Indicate the intensity level, totally 15 levels.

2. MODE

p Show stimulation mode & type of current stimulation.

3. PROGRAM

p Display the current stimulation program, totally 6 programs.

4. LOCK

p Turn on when program is locked.

5. PAD TYPE

p Indicate if current output is for 2 or 4 pads.

6. TIMER

Show remaining treatment time.

7. BATTERY LOW

Flash when battery low.

8. FREQUENCY ADJUSTMENT

"Manual Icon" turns on when frequency can be adjusted.

"Auto Icon" turns on when frequency cannot be adjusted.

4. Operations

ij) Place the electrode

- ① Connect the electrode to the cable.
- ② Place the electrode to your body.
- ③ Connect the cables(s) to the device.

ii) Turn on the device

-Press **ON/OFF KEY**. LED displays when the device is on. Always switch the device off before removing electrodes from the skin.

iii) Select a program

- Use **MODE KEY** to choose a desirable program from Program 1 to Program 6.
- The output intensity resets to zero when you change a treatment program.

iv) Set you own program

-A practitioner can choose a desirable program, adjust a suitable beat frequency and treatment timer, pad time for his/her patients and then lock the program by following steps mentioned in point iii, and v to viii.

v) 2/4 Pads Mode Button

Press **2/4 KEY** to choose either 2-Pads or 4-pads treatment mode. When 2/4 Pads mode is changed, the output intensity resets to zero.

In 4-PADS TREATMENT MODE, 2 sinusoidal outputs with different frequencies will be delivered to Channel 1 and 2 respectively. Channel 1 delivers a fixed 4kHz sine wave while Channel 2 delivers a sine wave with frequency ranges between 4002Hz and 4160Hz.

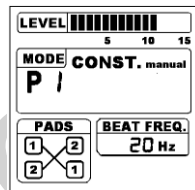

In 2-PADS TREATMENT MODE, 2 sine waves will be superimposed inside the device to form a new amplitude-modulated waveform. The resulting output is simultaneously delivered to Channel 1 and 2.

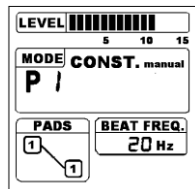

vj) Adjust the Intensity

You can adjust a desired intensity by pressing the **LEVEL +** or **LEVEL -** accordingly.

vii) Adjust the Beat Frequency

You can also change a frequency by pressing the **FREQ. +** and **FREQ. -** when the LCD displays the word “Manual”.

The output beat frequency ranges between 2Hz and 160Hz.

viii) Lock and Unlock your own program

To lock a program, firstly please adjust the “Level” Bar to zero, then press & hold **2/4 KEY** for 2 seconds. Whenever you turn on the device again, the program will come up.

To unlock the program, take the same step. i.e. To press the **LEVEL -** till to zero, then press & hold **2/4 KEY** for 2 seconds.

ix) Treatment Timer

Press **Timer KEY** to select your desired treatment period ranging from 15, 30, 45 and 60 minutes. If no timer is set, the device will provide a continuous output, and no “CLOCK” symbol will be displayed.

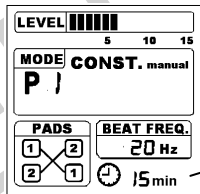

Treatment Timer

Once you fix a treatment timer, the timer starts its calculation only if the output level

(Level Bar) is non-zero. When the treatment timer is operated, the output intensity will no longer affect its operation. The treatment timer begins to count down from its preset value. You can notice the timer value from the LCD at every minute interval. When the preset treatment period is elapsed, the device switches off its output.

x) Usage Timer

Once you start the stimulation with output (i.e. non-zero Level Bar), the User Timer automatically and accumulatively counts your total usage up to 999 hours 59 minutes. The User Timer resets to zero when this limit is reached.

To view the Usage Timer, set **LEVEL -** to zero, then press & hold the **TIMER KEY** for 2 seconds.

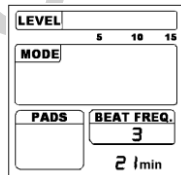

The Usage Timer at the right LCD displays the total usage of 3 hour 21 minutes

To cancel the accumulated Usage Timer, press the **TIMER KEY** for another 2 seconds and it starts at zero again. After 2 second eclipsed, LCD will show back the ordinary contents.

5. Treatment Programs

- You can choose 6 different treatment programs.

-When treatment program changes, the output intensity and treatment time resets to zero, but changing the treatment program will not alter the choice of the 2-Pads or 4-Pads Treatment.

| Program | Type | I/F frequency adjustable | Description |
|---------|----------|--------------------------|---|
| 1 | Constant | Yes | 2-160Hz Adjustable 2 to 20Hz adjustable in steps of 2 Hz. 20 to 80Hz adjustable in steps of 5Hz. 80 to 160Hz adjustable in steps of 10Hz. |
| 2 | Sweep | No | The beat frequency sweeps from 2Hz – 10Hz in 6 seconds, and then back in 6 seconds, total cycle time is 12 seconds. |
| 3 | Sweep | No | The beat frequency sweeps from 2 Hz to 100Hz in 10 seconds, and then back in 10 seconds, total cycle time is 20 seconds. |
| 4 | Sweep | Yes | The beat frequency changes gradually from the set value to +200% of it in 6 seconds, and then back in 6 seconds, total cycle time is 12 seconds. The selectable beat frequency ranges between 5 ~ 80Hz with steps of 5Hz. |
| 5 | Abrupt | Yes | The beat frequency changes abruptly between set value and +200% of it every 1 second. The total cycle repeats in 2 seconds. The selectable beat frequency ranges between 5-80Hz with steps of 5Hz. |
| 6 | Abrupt | Yes | The beat frequency changes abruptly between set value and +200% of it every 6 seconds. The total cycle repeats in 12 seconds. The selectable frequency ranges between 5~80Hz with step of 5Hz. |

6. Placement of Electrodes

- The placement of the electrodes is very important to the success of the treatment, therefore please place electrodes according to the instructions of your treating physician.
- When operating in 4-Pads treatment mode, the electrodes should be placed on the body as described in the diagram below. The arrangement of these 4 electrodes will allow the intersection of the 2 sinusoidal outputs, which will result in the required beat frequency. In 2-Pads treatment mode, 2 separate pairs of electrodes can simultaneously treat two different body regions.

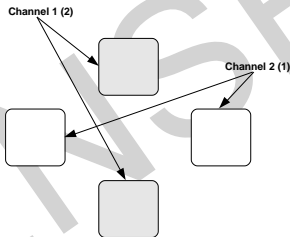

7. Battery replacement

- Slide out the battery holder located at the bottom of the device
- Take the used battery out of the holder and place a new battery
- Check the polarity (+ at the front side)
- Slide the battery holder back to the device
- Check the functions by pressing the keys

8. Maintenance

The life of pads depends on the frequency and time of usage as well as the skin types and storage conditions. You may use a wet cloth for the dried or dirty pads, but the pads with no adherence must be replaced.

The device requires neither routine maintenance nor calibration. When needed, for occasional cleaning/disinfecting of the plastic covers, use alcohol wiping.

IMPORTANT. Only use the AC adaptor supplied together with the device. Use of other adaptors may compromise safety.

9. Warranty

Warranty is voided immediately as to any Product which has been repaired or modified by any person other than authorized dealer or supplier or which has been subjected to misuse, abuse, neglect, damage in transit, accident or negligence.

10. Device failures

DO NOT repair damaged devices yourselves. In the event of a fault, please contact the dealer or supplier for assistance.

Manufactured for:

Current Solutions, LLC
3814 Woodbury Drive
Austin, TX 78704

11. Troubleshooting

| Problem | Check point | Solution |
|--------------------------|--|---|
| No indication / No start | <i>Check the battery:</i> -Is battery dead? -Correct polarity? | -Replace with new battery. -Put the battery properly. |
| Bad contact indication | <i>Check the pads:</i> -Firmly placed? -Dried or dirty surface? <i>Check the electrode pins to pads:</i> -Firmly connected? <i>Check the skin:</i> -Too dry? | -Press the pads to the skin. -Replace with new pads -Connect to the pads -Moisturize the skin with a wet towel. |
| Skin irritation | <i>Check the pads:</i> -Firmly placed? -Dried or dirty? <i>Check the skin:</i> -Scar, cut or damage? -Too dry? -Applied chemicals? -Allergy? | -Press the pads to the skin. -Replace new pads. -Avoid the damaged area. -Moisturize the skin with a wet towel -Remove all chemicals or cosmetics from the skin. -Stop using and consult a doctor. |

12. Specifications

| | |
|-------------------------------|--|
| Channel | Dual, isolated between channels |
| Mode | 6 operation programs |
| Waveform | Symmetrical Balanced Sine Wave |
| Output Current | Adjustable, 0-33 mA across 500 Ohm load on each channel |
| Beat Frequency | 2-160 Hz |
| Carrier Frequency | 4000Hz (with $\pm 1\%$ tolerance) fixed on Channel 1 |
| Modulating Frequency | 4002 – 4160Hz (with $\pm 1\%$ tolerance) adjustable on Channel 2 |
| Power Source | 4 x 1.5V AA Size battery OR AC/DC adaptor(Input:100-240V AC ; Output: 6V, 1A DC) |
| Low Battery Detection | 4.0V \pm 0.1V |
| Treatment Timer | Continuous, 15, 30, 45 or 60 minutes |
| Usage Timer | Maximum 999 hours, 59 minutes |
| Automatic Power Off | If the output is continually remained at zero for 5 minutes, the device will then be automatically shut down. |
| Output Configuration | <u>4-Pads Treatment</u> Conventional Interferential Current Therapy (IFC) with Channel 1 delivers a fixed 4kHz sine wave, while output of Channel 2 can be varied between 4002Hz and 4160Hz. <u>2-Pads Treatment</u> Pre-modulated Interferential Current Therapy (IFC) in which both Channel 1 and 2 will simultaneously deliver an amplitude-modulated output with beat frequency varies between 2 and 160Hz. |
| Environment For Storage & Use | Temperature 0-40°C Air humidity 30-75% Air pressure 700hPa-1060hPa |
| Expected Service Life | 5 years |

13. Important symbols



We confirm that the device complies with Directive 93/42/EEC



Please read the manual carefully before using the device.



Device with this symbol is an IEC/EN60601-1 type BF equipment. It provides a high degree of protection against electric shock.



Disposal of the appliance

Legislation requires that all electrical and electronic equipment must be collected for reuse and recycling. Electrical and electronic equipment marked with the symbol indicating separate collection of such equipment must be returned to a municipal waste collection point at the end of its service lifetime.

The device is intended for continuous use with no degree of protection against water penetration.



Medical Devices Directive 93/42/EEC
Reserve the rights for running changes.

FOR USA MARKET

Caution: Federal Law restricts this device to sale or use by or on the order of a practitioner so licensed by the State.

Ver.1, 13-Aug-09