

CARETEC™ II

INSTRUCTION MANUAL



**This manual is valid for the CareTec™ II
TENS/EMS Stimulator**

This user manual is published by Current Solutions™, LLC

Current Solutions™, LLC does not guarantee its contents and reserves the right to improve and amend it at any time without prior notice. Amendments may however be published in new editions of this manual.

All Rights Reserved.Rev.V1.0 © 2011



United States Federal Law restricts this device to sale by or on the order of a physician or licensed practitioner

Conformity to safety standards

Current Solutions™, LLC declares that the device complies with following normative documents:

**IEC60601-1, IEC60601-1-2, IEC60601-2-10, IEC60601-1-4,
ISO10993-5,ISO10993-10, ISO10993-1**

Table of Contents

1. Safety information.....	4
1.1 General description	
1.2 Medical background	
1.3 Indication for use	
1.4 Contraindications	
1.5 Warnings, Cautions, Adverse Reactions	
2. Presentation	11
2.1 Front and Rear panel	
2.2 LCD display	
3. Specification.....	14
3.1 Accessories	
3.2 Technical information	
3.3 The waveforms of the stimulation programs	
4. Instruction for use	19
4.1 Battery	
4.2 Connect electrodes to lead wires	
4.3 Connect lead wires to device	
4.4 Electrode	
4.5 Turn ON	
4.6 Select the Therapeutic Mode	
4.7 Steps to set a new program	
4.8 Adjust Channel Intensity	
4.9 Lock the button	
4.10 Stop the treatment	
4.11 Turn OFF	
4.12 Low battery indicator.	
5. Program.....	28
6. Cleaning and Care	29
6.1 Tips for skin care	
6.2 Cleaning the device	
6.3 Electrodes	
6.4 Cleaning the Electrodes cords	
6.5 Maintenance	
7. Troubleshooting.....	32
8. Storage.....	34
9. Disposal.....	34
10. Electromagnetic Compatibility (EMC) Tables.....	35
11. Glossary of symbols.....	41
12. Warranty.....	42

1. Safety Information

1.1 General

CareTec™ II Electrical Stimulator is a portable electrotherapy device featuring two therapeutic modes: **Transcutaneous Electrical Nerve Stimulator** and **Electrical Muscle Stimulation** which are used for pain relief and electrical muscle stimulation. The stimulator sends gentle electrical current to underlying nerves and muscle group via electrodes applied on the skin. The parameters of device are controlled by the channel buttons. Its intensity level is adjustable according to the needs of patients.

1.2 Medical background

EXPLANATION OF TENS

Transcutaneous Electrical Nerve Stimulation (TENS) is a non-invasive, drugfree method of controlling pain. TENS uses electrical impulses sent through the skin to nerves to modify your pain perception. TENS does not cure any physiological problem; it only helps control the pain. TENS does not work for everyone; however, in most patients it is effective in reducing or eliminating the pain, allowing for a return to normal activity.

EXPLANATION OF EMS

Electrical Muscle Stimulation (EMS) is an internationally accepted and proven way of treating muscular injuries. It works by sending electronic pulses to the muscle needing treatment; this causes the muscle to exercise passively. It is a product derived from the square waveform (ladder-shaped). Through the square wave pattern it is able to work directly on muscle motor neurons. This device has low frequency and this in conjunction with the square wave pattern allows direct work on muscle groupings. This is being widely used in hospitals and sports clinics for the treatment of muscular injuries and for the re-education of paralyzed muscles, to prevent atrophy in affected muscles and improving muscle tone and blood circulation.

1.3 Indication for use

CareTec™ II electrical stimulator may be used for the following conditions:

- 1) Symptomatic relief of chronic intractable pain; Post traumatic pain; post surgical pain.
- 2) Relaxation of muscle spasm.
- 3) Increase of blood flow circulation
- 4) Prevention of disuse atrophy
- 5) Muscle re-education
- 6) Maintaining or increasing range of motion.
- 7) Immediate post-surgical stimulation of calf muscles to prevent venous thrombosis

IMPORTANT SAFETY INFORMATION!

Read instruction manual before operation. Be sure to comply with all "Contraindications", "Warnings", "Cautions" and "Adverse reactions" in the manual. Failure to follow instructions can cause harm to user or device.

1.4 Contraindications

- 1) This device should not be used for symptomatic local pain relief unless etiology is established or unless a pain syndrome has been diagnosed.
- 2) This device should not be used when cancerous lesions are present in the treatment area.
- 3) Stimulation should not be applied over swollen, infected, inflamed areas or skin eruptions (e.g. phlebitis, thrombophlebitis, varicose veins, etc.).
- 4) Electrodes must not be applied to sites that might cause current/stimulation to flow through the carotid sinus region (anterior neck) or transcranially (through the head).
- 5) Do not use this device if the patient has a demand-type cardiac pacemaker or any implanted defibrillator.

- 6) This device should not be used over poorly enervated areas.
- 7) Epilepsy
- 8) Serious arterial circulatory problems in the lower limbs
- 9) Abdominal or inguinal hernia
- 10) Do not use this device if you have heart disease without consulting your physician.

1.5 Warnings, Cautions and Adverse Reactions

WARNINGS:

- 1) This device should be used only under the continued supervision of a licensed physician.
- 2) The long-term effects of chronic electrical stimulation are unknown. Electrical stimulation devices do not have any curative value.
- 3) TENS is a symptomatic treatment and, as such, suppresses the sensation of pain, which would otherwise serve as a protective mechanism.
- 4) Safety has not been established for the use of therapeutic electrical stimulation during pregnancy. Do not use during pregnancy unless directed by your physician.
- 5) Electrical stimulation is not effective for pain of central origin.
- 6) Electronic monitoring equipment (such as ECG monitors and ECG alarms) may not operate properly when electrical stimulation is in use.
- 7) Stimulation should not be applied over the carotid sinus nerves, particularly in patients with a known sensitivity to the carotid sinus reflex.
- 8) Stimulation should not be applied over the neck or mouth. Severe spasm of the laryngeal and pharyngeal muscles may occur and the contractions may be strong enough to close the airway or cause difficulty in breathing.
- 9) Stimulation should not be applied transthoracically in that the introduction of electrical current into the heart may cause cardiac arrhythmias.

- 10) Stimulation should not take place while the user is connected to high-frequency surgical equipment, it may cause burn injuries on the skin under the electrodes, as well as problems with the stimulator.
- 11) Do not use the stimulator in the vicinity of shortwave or microwave therapy equipment, since this may affect the output power of the stimulator.
- 12) Never use in environments with high humidity such as in the bathroom or when having a bath or shower.
- 13) Caution should be used in applying electrical stimulation to patients suspected of having heart disease. Further clinical data is needed to show there are no adverse results.
- 14) Never use near the heart. Stimulation electrodes should never be placed anywhere on the front of the thorax (marked by ribs and breastbone), but above all not on the two large pectoral muscles. Here it can increase the risk of ventricular fibrillation and lead to cardiac arrest.
- 15) Electrodes should not be placed over the eyes, in the mouth, near the genitals or internally.
- 16) Never use on the areas of the skin which lack normal sensation
- 17) Apply the electrodes to clean, dry, and unbroken skin only.
- 18) Keep electrodes separate during treatment, electrodes in contact with other could result in improper stimulation or skin burns.
- 19) Keep the stimulator out of reach of children.
- 20) Consult your doctor if you are in any doubt whatsoever.

CAUTIONS:

- 1) Federal law (USA) restricts this device to sale by or on the order of a physician.
- 2) For single patient use only.
- 3) Keep yourself informed of the contraindications.
- 4) This stimulator not intended for unattended, personal use by patients who have noncompliant, emotionally disturbed, dementia, or low IQ.

- 5) Read, understand, and practice the warnings, cautions and operating instructions. Know the limitations and hazards associated with using any device. Observe the precautionary and operational decals placed on the unit. Always follow the operating instructions prescribed by your healthcare practitioner.
- 6) The instruction of use was listed; any improper use may be dangerous.
- 7) Do not use this device for undiagnosed pain syndromes until consulting a physician.
- 8) Patients with an implanted electronic device, such as a cardiac pacemaker, implanted defibrillator, or any other metallic or electronic device should not use this device without first consulting a doctor.
- 9) Stimulation delivered by this device may be sufficient to cause electrocution. Electrical current of this magnitude must not flow through the thorax or across the chest because it may cause a cardiac arrhythmia.
- 10) Do not place electrodes on the front of the throat as spasm of the Laryngeal and Pharyngeal muscle may occur. Stimulation over the carotid sinus (neck region) may close the airways, make breathing difficult, and may have adverse effects on the heart rhythm or blood pressure.
- 11) Do not place electrodes on your head or at any sites that may cause the electrical current to flow transcranially (through the head).
- 12) Patients with heart disease, epilepsy, cancer or any other health condition should not use this device without first consulting a physician.
- 13) Some patients may experience skin irritation or hypersensitivity due to the electrical stimulation or silicone rubber. If rash develops or pain persists, discontinue use and consult a doctor.
- 14) Electrode placement and stimulation settings should be based on the guidance of prescribing practitioner.
- 15) Effectiveness is highly dependent upon patient selection by a person qualified in the management of pain afflicted patients.
- 16) Isolated cases of skin irritation may occur at the site of the electrode placement following long-term application. If this occurs, discontinue use and consult your physician.
- 17) The electrodes are only to be placed on healthy skin. Avoid skin irritation by ensuring that good contact is achieved between electrodes and skin.
- 18) If the stimulation levels are uncomfortable or become uncomfortable, reduce the stimulation intensity to a comfortable level and contact your physician if problems persist.
- 19) This device should not be used while driving, operating machinery, close to water, or during any activity in which involuntary muscle contractions may put the user at undue risk of injury.
- 20) Never use the device in rooms where aerosols (sprays) are used or pure oxygen is being administered.
- 21) Do not use it near any highly flammable substances, gases or explosives.
- 22) Do not use this device at the same time as other equipment which sends electrical pulses to your body.
- 23) Do not confuse the electrode cables and contacts with your headphones or other devices, and do not connect the electrodes to other devices.
- 24) Do not use sharp objects such as pencil point or ballpoint pen to operate the buttons on the control panel.
- 25) Inspect Applicator cables and associated connectors before each use.
- 26) Turn the device off before applying or removing electrodes.
- 27) Electrical stimulators should be used only with the leads and electrodes recommended for use by the manufacturer
- 28) This device has no AP/PG protection. Do not use it in the presence of explosive atmosphere and flammable mixture.

Adverse Reactions:

- 1) Skin irritation from the electrode gel and electrode burns are potential adverse reactions. If skin irritation occurs, discontinue use and consult your physician.
- 2) If the stimulation levels are uncomfortable, reduce the stimulation intensity to a comfortable level and contact your physician if problems persist.

2. Presentation

2.1 Front and Rear Panel

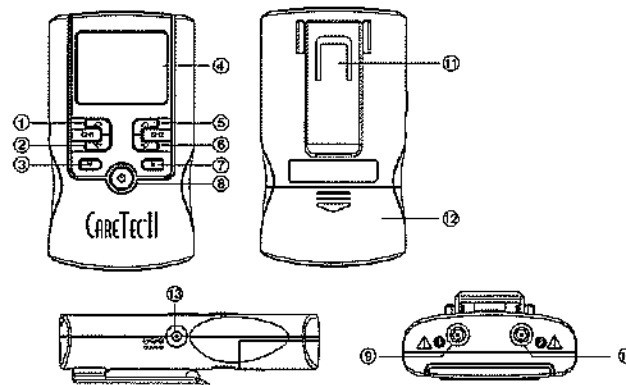

- 1) Increasing the output intensity of channel 1 [▲]. To set the application program and the parameter of the waveform in the setting state.
- 2) Decreasing the output intensity of channel 1 [▼]. To set the application program and the parameter of the waveform in the setting state. To unlock the current treatment program.
- 3) Therapeutic mode selection [M]. Stop the treatment. Exit setting mode to the user interface.
- 4) LCD display: Shows the operating state of the device.
- 5) Increasing the output intensity of channel 2 [▲]. To set the application program and the parameter of the waveform in the setting state.
- 6) Decreasing the output intensity of channel 2 [▼]. To set the application program and the parameter of the waveform in the setting state. To unlock the current treatment program.

- 7) Parameter Selection [S]: press the button to enter setting state; you can select the difference parameters in conjunction with [▲] and [▼].
- 8) Turn OFF/ON: press the [⏻] button to turn on the device or keep [⏻] button for approx.3 seconds to turn off the device.
- 9) Output socket: electric signal output after connection of the cable with adhesive electrodes channel 1
- 10) Output socket: electric signal output after connection of the cable with adhesive electrodes channel 2
- 11) Belt Clip
- 12) The battery compartment cover for opening
- 13) Adapter Receptacle

2.2 LCD display

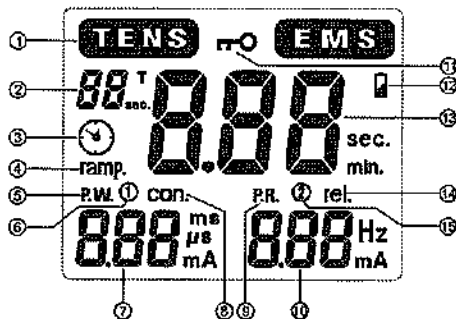

- 1) Display therapeutic mode
- 2) Display therapeutic program or Display the cycle time for TENS therapeutic mode in setting state.
- 3) Timer symbol
- 4) EMS waveform of ramp up and ramp down time
- 5) Display of waveform pulse width
- 6) Display the channel 1

- 7) Display numbers of the output intensity for channel 1(CH1); Display numbers of waveform pulse width or EMS waveform of contraction (working) time in setting state.
- 8) EMS waveform of contraction (working) time
- 9) Display of waveform pulse rate
- 10) Display numbers of the output intensity for channel 2(CH2); Display numbers of waveform pulse rate or EMS waveform of relaxation time in setting state.
- 11) The device is locked indicator
- 12) Low-battery indicator
- 13) Display numbers of the treatment time or EMS waveform of ramp up and ramp down time
- 14) EMS waveform of relaxation time
- 15) Display the channel 2

3. Specification

3.1 Accessories

No	DESCRIPTION	Q'TY
1	Electrical stimulator device	1 piece
2	Electrodes Leads	2 pieces
3	1.5"x1.5"Adhesive Electrodes	4 pieces
4	9V Battery, type 6F22	1 piece
5	Instruction Manual	1 piece
6	Carrying case	1 piece

3.2 Technical information

Channel	Dual, isolated between channels
Power supply	9.0V DC -1x6F22 battery Adapter output:9.0Vdc, 800mA
Operating conditions	5°C to 40°C (41 °F to 104 °F)with a relative humidity of 30%-75%, atmospheric pressure from 700 to 1060 Hpa
Storage conditions	-10°C to 50°C (14 °F to 122 °F) with a relative humidity of 10%-90%,atmospheric pressurefrom 700 to 1060 Hpa
Dimensions	4.5x2.55x0.9 inches(L*W*H)
Weight	0.28 lbs(With battery)
Tolerance	There may be a ±5% tolerance of all setting and ±10% tolerance of output of intensity.
Timer	Adjustable, from 1 to 60 minutes or continuous. Adjustable in 1minutes each step. Treatment time countdown automatically.

Technical specifications for Transcutaneous Electrical Nerve Stimulator (TENS) mode

Waveform	Mono-phase square pulse wave
Pulse amplitude	Adjustable, 0~100mA peak at 1000 ohm Load each channel, 1mA/Step.
Pulse Width	Adjustable, from 50 to 300us microseconds, 10µS/step
Pulse Rate	Adjustable, from 1 to 150 Hz, 1 Hz/step
Burst (P1)	Burst rate: Adjustable, 0.5 ~ 5Hz; 0.1Hz/step Pulse width adjustable, 50~300µS Frequency fixed = 100 Hz
Normal (P2)	The pulse rate and pulse width are adjustable. It generates continuous stimulation based on the setting value.
Pulse Width Modulation (P3)	The pulse width is automatically varied in a cycle time. The pulse width is decreased from its original setting to 60% in setting cycle time, and then increased from 60% to its original setting in next setting cycle time. In this program, pulse rate (1 to 150Hz), pulse width (50 to 300us) and cycle time (5 to 30 sec) are fully adjustable.
Pulse Rate Modulation (P4)	The pulse rate is automatically varied in a cycle time. The pulse rate is decreased from its original setting to 60% in setting cycle time, and then increased from 60% to its original setting in next setting cycle time. In this program, pulse rate (1 to 150Hz), pulse width(50 to 300us) and cycle time (5 to 30 sec) are fully adjustable.

Technical specifications for Electrical Muscle Stimulation (EMS) mode

Waveform	Mono-phase square pulse wave
Pulse amplitude	Adjustable, 0~100mA peak at 1000 ohm Load each channel, 1mA/Step.
Pulse Width	Adjustable, from 50 to 300 μ S microseconds, 10 μ S/step.
Pulse Rate	Adjustable, from 1 to 150 Hz, 1 Hz/step
Contraction time	Adjustable, 1~30 seconds , 1 Sec./ step
Relaxation (OFF)time	Adjustable, 0~60 seconds , 1 Sec./ step
Ramp time	Adjustable, 1~6 seconds, 1 Sec. / step, The "On" time will increase and decrease in the setting value.
Synchronous (P1)	Stimulation of both channels occurs synchronously. The "ON" time including "Contraction", "Ramp Up" and "Ramp Down" time. ON TIME=Contraction + Ramp up + Ramp down
Alternate (P2)	The Stimulation of the CH2 will occur after the 1st working of CH1 is completed. In this program, The "ON" time including "Contraction", "Ramp Up" and "Ramp Down" time. The OFF Time should be equal or more than the ON Time ON TIME=Contraction + Ramp up + Ramp down OFF TIME \geq ON TIME
Delay (P3)	The Stimulation of the CH2 will occur after the 1st working of CH1 is started+ Delay Time. Delay time is adjustable form 1 to 10 sec. In this program, The "ON" time including "Contraction", "Ramp Up" and "Ramp Down" time. ON TIME=Contraction + Ramp up + Ramp down

3.3 The waveforms of the stimulation programs

Burst

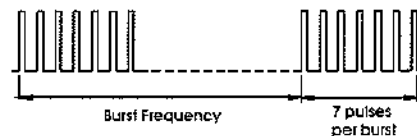

Normal

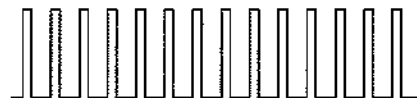

Pulse Width Modulation

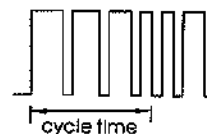

Pulse Rate Modulation

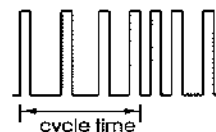

Synchronous

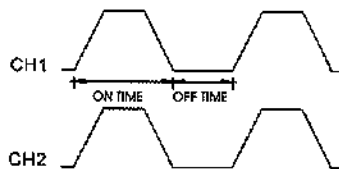

Alternate

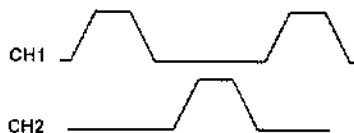

Delay

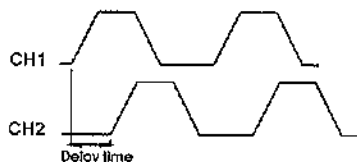

4. Instruction for use

4.1 Battery

4.1.1 Check/Replace the battery

Over time, in order to ensure the functional safety of device, changing the battery is necessary.

- 1) Slide the battery compartment cover and open.
- 2) Insert the 9V battery into the battery compartment.
- 3) Make sure you are installing the battery properly. Be sure to match the positive and negative ends of the battery to the marking in the battery compartment of the device.
- 4) Press and pull down following the direction of the arrow indicated on the photo.
- 5) Replace the battery compartment cover and press to close.
- 6) If replace the battery, you should slide the battery compartment cover and open. Pull up the battery following the direction of the arrow indicated on the photo. And insert the 9V battery according to the above step 2) to 5).

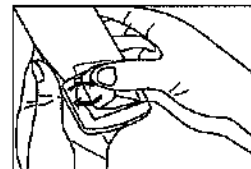

4.1.2 Disposal of battery

Spent batteries do not belong in the household waste. Dispose of the battery according to the current federal, state and local regulations. As a consumer, you are obligated by law to return spent battery.



Caution:

- 1) **Battery may be fatal if swallowed. Therefore, keep the battery and the product out of the range of children, if a battery was swallowed, consult a physician immediately.**
- 2) **If a battery has leaked, avoid contact with skin, eyes and mucus membranes, Rinse the affected spots with lots of clear water immediately and contact a physician right away.**

- 3) *Battery may not be charged, dismantled, thrown into fire or short-circuited.*
- 4) *Protect battery from excess heat; Take the battery out of the product if they are spent or in case you no longer use the article. This prevents damage caused by leaking battery.*
- 5) *Always replace the same type battery.*

4.2 Connect electrodes to lead wires

Insert the lead wire connector into electrodes connector (standard 0.08 inch female connection). Make sure no bare metal of the pins is exposed.

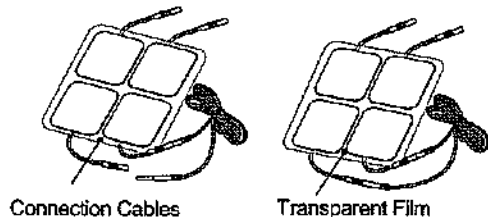

Caution:

Please always use FDA approved electrodes.

4.3 Connect lead wires to device

- 1) Before proceeding to this step, be sure the device is completely turns OFF.
- 2) The wires provided with the system insert into the jack sockets located on top of the device.
- 3) Holding the insulated portion of the connector, push the plug end of the



wire into one of the jacks (see drawing); one or two sets of wires may be used.

- 4) This device has two output receptacles controlled by Channel 1 and Channel 2 at the top of the unit. You may choose to use one channel with one pair of lead wires or both channels with two pairs of lead wires. Using both channels gives the user the advantage of stimulating two different areas at the same time.

Caution:

Do not insert the plug of the patient lead wire into any AC power supply socket.

4.4 Electrode

4.4.1 Electrode options

The electrodes are disposable and should be routinely replaced when they start to lose their adhesive nature. If you are unsure of your electrode adhesive properties, order replacement electrodes. Replacement electrodes should be re-ordered through or on the advice of your physician to ensure proper quality. Follow application procedures outlined in electrode packing, to maintain optimal stimulation and to prevent skin irritation.

4.4.2 Place electrodes on skin

Apply electrodes to the exact site indicated by your physician or therapist, before applying electrodes, be sure the skin surface over which electrodes are placed is thoroughly cleaned and dried. Make sure the electrodes are placed firmly to the skin and make good contact between the skin and the electrodes. Place the electrodes over the skin; attach them properly, firmly, and evenly.

Caution:

- 1) *Before applying the self-adhesive electrodes, it is recommended to wash and degrease the skin, and then dry it.*
- 2) *Do not turn on the device when the self-adhesive electrodes are not positioned on the body.*
- 3) *Never remove the self-adhesive electrodes from the skin while the device is still turned on.*
- 4) *It is recommended that, at minimum, 1.5" x 1.5" self-adhering based, square electrodes are used at the treatment area.*

4.4.3 Electrode placement

The placement of electrodes can be one of the most important parameters in achieving success with therapy. Of utmost importance is the willingness of the physician to try the various styles of electrode placement to find which method best fits the needs of the individual patient.

Every patient responds to electrical stimulation differently and their needs may vary from the conventional settings suggested here. If the initial results are not positive, speak to your physician about alternative stimulation settings and/or electrode placements. Once an acceptable placement has been achieved, mark down the electrodes sites and the settings, so the patient can easily continue treatment at home.

4.5 Turn on

Before using the device for the first time, you are strongly advised to take careful note of the counter-indications and safety measures detailed at the beginning of this manual (Safety information), as this powerful equipment is neither a toy nor a gadget! In order to turn on the device, keep the [⏻] button pressed down until the operation page appears on the screen.

4.6 Select the Therapeutic Mode

There are 2 therapeutic modes available – TENS and EMS. The therapeutic mode can be selected by pressing the [M] control.

Caution:

Consult your physician for your suitable therapeutic mode

4.7 Steps to Set a New Program

4.7.1 TENS Setting

Press the [S] button cycle to enter the setting state. The settings can be adjusted according to the following steps:

1) Set the Therapeutic Program

There are 4 programs in TENS therapeutic mode available – Burst (P1), Normal (P2), Pulse Width Modulation (P3), and Pulse Rate Modulation (P4). The therapeutic program can be selected by pressing the [▲] and [▼] button. When you choose to [B] program, program [B] outside of the box will be flashing.

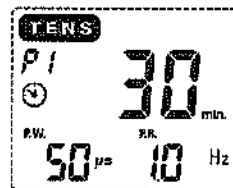

2) Set Cycle Time (Optional)

Cycle time is adjustable from 5 to 30 seconds. Only modulation has this parameter setting. Press [S] button cycle to enter this menu, and then press the [▲] and [▼] button to adjusting the setting.

3) Set Timer

Press [S] button cycle to enter this setting. The treatment time is adjustable from 1 to 60 minutes or Continue. Press [▲] or [▼] button control to adjust setting. You can set the timer to "Continuous" mode by pressing the [▲] control when it shows 60 minutes. Its output will be shut off when time is up.

4) Set Pulse Width

Pulse Width is adjustable from 50 uS to 300 uS. Press [S] button to enter this menu, then press [▲] or [▼] button to adjust the setting.

5) Set Pulse Rate

Pulse rate is adjustable from 1 Hz to 150 Hz (0, 5 Hz to 5 Hz for Burst). Press [S] button cycle to enter this menu, and then press [▲] or [▼] button to adjust the setting.

4.7.2 EMS Setting

Press the [S] button cycle to enter the setting state. The settings can be adjusted according to the following steps:

1) Set the Therapeutic Program

There are 3 programs in EMS therapeutic mode available – Delay (P1), Synchronous (P2) and Alternate (P3). The therapeutic program can be selected by pressing the [▲] and [▼] button. When you choose to [S] program, program [S] outside of the box will be flashing.

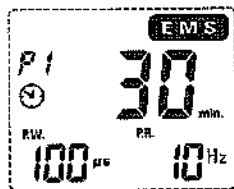

2) Set Timer

Press [S] button cycle to enter this setting. The treatment time is adjustable from 1 to 60 minutes or Continue. Press [▲] or [▼] control to adjust setting. You can set the timer to "Continuous" mode by pressing the [▲] button when it shows 60 minutes. Its output will be shut off when time is up.

3) Set Pulse Width

The pulse width determines the length of time. Each electrical signal is applied through the skin, which controls the strength and sensation of the stimulation. Press [S] button cycle to enter this setting. The pulse width is adjustable from 50 to 300 uS. Press [▲] or [▼] button to adjust the setting.

4) Set Pulse Rate

The pulse rate determines how many electrical impulses are applied through the skin each second. Press [S] button cycle to enter this menu. By the [▲] or [▼] button to adjusting the setting. The pulse rate is adjustable from 1 Hz to 150 Hz.

5) Set Delay Time(Optional)

Delay time is adjustable form 1 to 10 seconds. Only Delay therapeutic program has this parameter setting. Press [S] button cycle to enter this menu, and then press the [▲] and [▼] button to adjusting the setting.

6) Set Ramp Time

The ramp time controls the time of output current that increase from 0 to the setting level, and from the setting value to 0. When the ramp time is set, each contraction may be ramped up and down in order that the signals come on and come off gradually and smoothly. The ramp time is adjustable from 1 to 6 seconds.

7) Set Contract Time

The contract Time controls the time of stimulation. The contraction time can be adjusted. Press [S] button cycle to enter this menu, and then press the [▲] and [▼] button to adjusting the setting. Both channels' stimulation is cycled on and off by the contraction and relaxation settings. The range is adjustable from 1 to 30 seconds.

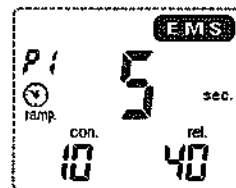

Caution:

Contract time has not including the ramp up and ramp down time, ON time=Ramp up + Contract time + Ramp down.

8) Set Relaxation (OFF) time

The Off Time controls the time of relaxation. The relaxation time can be adjusted. Press [S] button cycle to enter this menu, and then press the [▲] and [▼] button to adjusting the setting. Both channels' stimulation is cycled on and off by the contraction and relaxation settings. The range is adjustable from 0 to 60 seconds. In Alternate program, the OFF Time should be equal or more than the ON Time. (OFF TIME \geq ON TIME)

4.8 Adjust Channel Intensity

Press the intensity control button ([▲] and [▼]) to control the intensity output. Slowly press the intensity button control until you reach the setting recommended by your physician or therapist. Repeat for the other channel, if both channels are to be used.

Caution:

- 1). If the stimulation levels are uncomfortable or become uncomfortable, reduce the stimulation intensity to a comfortable level and contact your medical practitioner if problems are still there.**
- 2). If the electrodes no placed firmly on skin or the device has not connected on the electrodes, the stimulator's output intensity surpasses 12mA, the intensity will nulls automatically.**

4.9. Lock the button

The Safety Lock Feature automatically activates after there is no operation in the panel for 30 seconds by locking out the ability to press the buttons. This is a safety feature to prevent accidental changes to your settings and to prevent accidental increases to the intensity levels. You can press either one of the [▼] buttons to unlock the device.

4.10. Stop the treatment

When you have activated the treatment timer, you can press the [M] button or the [▼] button to control stop the treatment.

Caution:

Default state, if the button is locked, you can press only one of the [▼] buttons to unlock, and then press the [M] button or the [▼] button to control stop the treatment.

4.11. Turn OFF

Press [⏻] button and hold for approx.3 seconds to Turn OFF the device.

Caution:

- 1). If there is no operation in the panel for 3 minutes in the waiting state, the device will be turns off automatically.**
- 2). In shutdown state, keep pressing the channel 2 [▼]first, and then press [⏻]button at the same to restore factory parameter settings.**

4.12. Low battery indicator

When the low power indicator flashes, the device will be turns off automatically, the battery should be replaced with a new one as soon as possible. However, the unit may continue to operate for a few more hours depends on the setting intensity level.

5. Programs

Mode	Program	Modulation Method	Frequency	Pulse Width	Treat time
TENS	P1	Burst	0.5-5Hz	50-300us	1-60min, continuous
	P2	Continuous	1-150Hz	50-300us	1-60min, continuous
	P3	Pulse width modulation	1-150Hz	50-300us	1-60min, continuous
	P4	Frequency modulation	1-150Hz	50-300us	1-60min, continuous
EMS	P1	Synchronous	1-150Hz	50-300us	1-60min, continuous
	P2	Asynchronous	1-150Hz	50-300us	1-60min, continuous
	P3	Delay	1-150Hz	50-300us	1-60min, continuous

6. Cleaning and Care

6.1 Tips for skin care

To avoid skin irritation, especially if you have sensitive skin, follow these suggestions:

- 1) Wash the area of skin where you will be placing the electrodes, using mild soap and water before applying electrodes, and after taking them off. Be sure to rinse soap off thoroughly and dry skin well.
- 2) Excess hair may be clipped with scissors; do not shave stimulation area.
- 3) Wipe the area with the skin preparation your clinician has recommended. Let this dry. Apply electrodes as directed.
- 4) Many skin problems arise from the "pulling stress" from adhesive patches that are excessively stretched across the skin during application. To prevent this, apply electrodes from centre outward; avoid stretching over the skin.
- 5) To minimize "pulling stress", tape extra lengths of lead wires to the skin in a loop to prevent tugging on electrodes.
- 6) When removing electrodes, always remove by pulling in the direction of hair growth.
- 7) It may be helpful to rub skin lotion on electrode placement area when not wearing electrodes.
- 8) Never apply electrodes over irritated or broken skin.

6.2 Cleaning the device

- 1) Remove the battery from the device every time when you clean it.
- 2) Clean the device after use with a soft, slight moistened cloth. In case of more extreme soiling you can also moisten the cloth with mild soapy water.
- 3) Do not use any chemical cleaners or abrasive agents for cleaning.

6.3 Electrodes

- 1) Use the device only with the leads and electrodes provided by the manufacturer. Use only the electrode placements and stimulation settings prescribed by your physician or therapist.
- 2) It is recommended that, at minimum, 1.5" x 1.5" self-adhering based, square electrodes are used at the treatment area.
- 3) Inspect your electrodes before every use. Replace electrodes as needed. Reusable electrodes may cause slight skin irritation, lose adhesion and deliver less stimulation if overused.

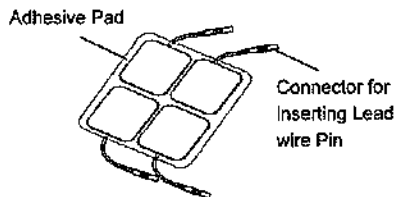

Reusable, Self-adhering electrodes

To use these electrodes:

- 1) Attach the electrode to the lead wire.
- 2) Remove the protective backing from the electrode surface.
Do not throw away the protective backing because it is reused after the treatment session has been completed.
- 3) Place the tacky surface to the prescribed skin area by pressing the electrode firmly against the skin.

To remove your electrodes:

- 1) Lift the corner of the electrode and gently remove it from the skin.
- 2) Apply the protective backing to the tacky side of the electrode. Place the electrode on the side of the protective backing that is labeled with the word on.
- 3) It may be helpful to improve repeated application by spreading a few drops of cold water over the adhesive and turn the surface up to air dry. Over Saturation with water will reduce the adhesive properties.

- 4) Between uses, store the electrodes in the resealable bag in a cool dry place.

Caution:

- **Do not pull on the electrode wire. Doing so may damage the wire and electrode.**
- **Do not apply to broken skin.**
The electrodes should be discarded when they are no longer adhering.
- **The electrodes are intended for single patient use only.**
- **If irritation occurs, discontinue use and consult your clinician.**
- **Read the instructions for use of self-adhesive electrodes before application.**
- **Always use the electrodes with CE mark, or are legally marketed in the US under 510(K) procedure.**

6.4 Cleaning the Electrodes cords

Clean the electrode cords by wiping them with damp cloth. Coating them lightly with talcum powder will reduce tangles and prolong the life.

6.5 Maintenance

- 1) Maintenance and all repairs should only be carried out by an authorized agency. The manufacturer will not be held responsible for the results of maintenance or repairs by unauthorized persons.
- 2) The user must not attempt any repairs to the device or any of its accessories. Please contact the retailer for repair.
- 3) Opening of the equipment by unauthorized agencies is not allowed and will terminate any claim to warranty.
- 4) Check the unit before each use for signs of wear and/or damage. Replace wear items as required.

7. Troubleshooting

If your device does not seem to be operating correctly, refer to the chart below to determine what may be wrong. Should none of these measures correct the problem, the device should be serviced.

Problem	Possible Cause	Solution
Displays fail to light up	Battery contact failure	1. Try fresh batteries. 2. Ensure batteries are inserted correctly. Check the following contacts: -All contacts are in place. -All contacts are not broken.
Stimulation weak	Electrodes 1. Dried out or contaminated 2. Placement Lead wires 1. Old/worn/damaged	Replace and re-connect Replace
Stimulation is uncomfortable	Intensity is too high Electrodes are too close together Damaged or worn electrodes or lead wires Electrode active area size is too small.	Decrease intensity. Reposition the electrodes. Replace. Replace electrodes with ones that have an active area no less than 16.0cm ² (4cm*4cm).

Intermittent output	Lead wires	1. Verify connection is secure. Insure firmly. 2. Turn down the intensity. Rotate lead wires in socket 90°. If still intermittent, replace lead wire. 3. If still intermittent after replacing lead wire, a component may have failed. Call the repair department.
	Program option in use	Some programs will seem intermittent. This is expected. Refer to the Program Option Controls in the Operation section for a description of the program option.
Stimulation is ineffective.	Improper electrode and applicator placement Unknown	Reposition electrode and applicator Contact clinician.

8. Storage

- 1) For a prolonged pause in treatment, store the device in a dry room and protect it against heat, sunshine and moisture.
- 2) Store the device in a cool, well-ventilated place
- 3) Never place any heavy objects on the device.

9. Disposal

Used fully discharged batteries must be disposed of in a specially labeled collection container, at toxic waste collection points or through an electrical retailer. You are under legal obligation to dispose of batteries correctly.

Please dispose of the device in accordance with the legal obligation.



10. Electromagnetic Compatibility (EMC) Tables

Guidance and manufacturer's declaration - electromagnetic emissions		
The device is intended for use in the electromagnetic environment specified below. The customer or the user assures that it is used in such an environment.		
Emissions test	Compliance	Electromagnetic environment - guidance
RF emissions CISPR 11	Group 1	The device uses RF energy only for its internal function. Therefore, its RF emissions are very low and are not likely to cause any interference in nearby electronic equipment.
RF emissions CISPR 11	Class B	The device is suitable for use in all establishments other than domestic and those directly connected to the public low-voltage power supply network that supplies buildings used for domestic purposes.
Harmonic emissions IEC 61000-3-2	Not applicable	
Voltage fluctuations /flicker emissions IEC 61000-3-3	Not applicable	

Guidance and manufacturer's declaration- electromagnetic immunity			
The device is intended for use in the electromagnetic environment specified below. The customer or the user should assure that it is used in such an environment.			
Immunity test	IEC 60601 test level	Compliance level	Electromagnetic environment - guidance
Electrostatic discharge (ESD) EC 61000-4-2	±6 kV contact ±8 kV air	±6 kV contact ±8 kV air	Floors should be wood, concrete or ceramic tile. If floors are covered with synthetic material, the relative humidity should be at least 30 %.

Guidance and manufacturer's declaration- Electromagnetic immunity			
The device is intended for use in the electromagnetic environment specified below. The customer or the user should assure that it is used in such an environment.			
Emissions test	IEC 60501 test level	Compliance level	Electromagnetic environment - guidance
Conducted RF IEC 61000-4-6	3 Vrms 150 kHz to 80 MHz	3 Vrms	Portable and mobile RF communications equipment should be used no closer to any part of the device, including cables, than the recommended separation distance calculated from the equation applicable to the frequency of the transmitter. Recommended separation distance $d=1.2 \sqrt{P}$ $d=1.2 \sqrt{P}$, 800MHz to 2,5MHz $d=1.2 \sqrt{P}$, 80MHz to 800MHz
Radiated RF IEC 61000-4-3	3 V/m 80 MHz to 2.5 GHz	3 V/m	

			<p>Where P is the maximum output power rating of the transmitter in watts (W) according to the Transmitter manufacturer and d is the recommended separation distance in meters (m).</p>
--	--	--	---

Field strengths from fixed RF transmitters, as determined by an electromagnetic site survey, should be less than the compliance level in each frequency range.

Interference  may occur in the vicinity of equipment marked with the following symbol:

NOTE 1 At 80 MHz ends 800 MHz, the higher frequency range applies.







NOTE 2 These guidelines may not apply in all situations. Electromagnetic propagation is affected by absorption and reflection from structures, objects and people.

1. Field strengths from fixed transmitters, such as base stations for radio (cellular/cordless) telephones and land mobile radios, amateur radio, AM and FM radio broadcast and TV broadcast cannot be predicted theoretically with accuracy. To assess the electromagnetic environment due to fixed RF transmitters, an electromagnetic site survey should be considered. If the measured field strength in the location in which the device is used exceeds the applicable RF compliance level above, should be observed to verify normal operation. If abnormal performance is observed, additional measures may be necessary, such as reorienting or relocating the device.

2. Over the frequency range 150 kHz to 80 MHz, field strengths should be less than [V] V/m.

11. Glossary of Symbols

Recommended separation distances between portable and mobile RF communications equipment and the device			
The device is intended for use in an electromagnetic environment in which radiated RF disturbances are controlled. The customer or the user of the device can help prevent electromagnetic interference by maintaining a minimum distance between portable and mobile RF communications equipment (transmitters) and the as recommended below, according to the maximum output power of the communications equipment:			
Rated maximum output power of transmitter W	Separation distance according to frequency of transmitter		
	150 kHz to 80 MHz $d=1.2 \sqrt{P}$	80 MHz to 800 MHz $d=1.2 \sqrt{P}$	800 MHz to 2,5 GHz $d=2.3 \sqrt{P}$
0.01	0.12	0.12	0.23
0.1	0.38	0.38	0.73
1	1.2	1.2	2.3
10	3.8	3.8	7.3
100	12	12	23
For transmitters rated at a maximum output power not listed above, the recommended separation distance d in meters (m) can be estimated using the equation applicable to the frequency of the transmitter, where P is the maximum output power rating of the transmitter in watts(W) accordable to the transmitter manufacturer. NOTE 1 At 80 MHz and 800 MHz, the separation distance for the higher frequency range applies. NOTE 2 These guidelines may not apply in all situations. Electromagnetic propagation is affected by absorption and reflection from structures, objects and people.			

	Batch code
	Serial number
	Electrical devices are recyclable material and should not be disposed of with household waste after their useful life! Help us to protect the environment and save resources and take this device to the appropriate collection points. Please contact the organization which is responsible for waste disposal in your area if you have any questions.
	Attention: Read the operating instruction before use!
	Degree of Electrical Protection BF
	Complies with the European Medical Device Directive (93/42/EEC) and amended by directive 2007/47/EC requirements. Notified body TÜV Rheinland (CE0197)

12. Warranty

Please contact your dealer in case of a claim under the warranty. If you have to send in the unit, enclose a copy of your receipt and state what the defect is.

The following warranty terms apply:

- 1) The warranty period for device is one year from date of purchase. In case of a warranty claim, the date of purchase has to be proven by means of the sales receipt or invoice.
- 2) Repairs under warranty do not extend the warranty period either for the device or for the replacement parts.
- 3) The following is excluded under the warranty:
 - All damage which has arisen due to improper treatment, e.g. nonobservance of the user instruction.
 - All damage which is due to repairs or tampering by the customer or unauthorized third parties.
 - Damage which has arisen during transport from the manufacturer to the consumer or during transport to the service centre.
 - Accessories which are subject to normal wear and tear.
- 4) Liability for direct or indirect consequential losses caused by the unit is excluded even if the damage to the unit is accepted as a warranty claim.